

असतो मा सद्गमय, तमसो मा ज्योतिर्गमय।।



**NEW INDIA SENIOR SECONDARY SCHOOL**  
**SECTOR-15, PANCHKULA**

Affiliated to CBSE  
[www.newindiapanchkula.in](http://www.newindiapanchkula.in)

# **WINTER BREAK**

## **ASSIGNMENT**

**DECEMBER 31, 2024 TO JANUARY 15, 2025**  
THE SCHOOL REOPENS ON JANUARY 16, 2025.



**CLASS-X**

Dear Parents

- Vacations are welcome break.....Break from schedules, rules and regulations of the school. Freedom brings more responsibility, so keeping this in mind, we have planned most of the activities to keep our children engaged and also help them in channelizing their energy. Kindly help and guide your child in completing his/her work and also exploring his/her creative self.

**Important Note:**

- Solve the given Practice Papers in your respective subject notebooks and submit on January 07, 2025.
- Prepare the given English and Hindi ASL topics.
- Prepare all Lab Practicals of Mathematics and Science for Annual Examination.

**HAPPY HOLIDAYS !**

# ENGLISH

## General Instructions:

- (i) *The Question Paper contains THREE sections- READING, GRAMMAR & WRITING and LITERATURE.*
- (ii) *Attempt questions based on specific instructions for each part.*

## SECTION-A (READING SKILLS)

### Q.1 Read the passage given below:

1. Mountains have always been held in great awe by mankind. They have been a challenge to humans. Those brave among us have always wanted to conquer them. You see, the more incredible the mountains, the greater the thrill – a challenge to the bravery of the human race. Climbing mountains is an experience that is hard to put into words. You are in a beautiful environment and, when you reach the top, you feel incredible. But you also have to climb down, which is when most accidents happen – people are tired, it gets dark, it's harder. So, mountain climbing is undoubtedly one of the most popular adventure sports along with being challenging and risky for the climber.

2. Without any perceived risk, there can't be a feeling that any significant challenge has been surmounted. Fair, but we have to bear in mind that mountaineering is not a sport that can be embraced without preparation. The enthusiasts must develop in themselves the spirit of adventure, willingness to undertake hardships and risks, extraordinary powers of perseverance, endurance, and keenness of purpose before climbing a mountain. They should also know how to handle the mountaineering equipment. Then comes the penance of the rigorous training. This could very well be the lifeline up there. It helps inculcate and hone survival instincts that allow the climber to negotiate perilous situations. There are numerous institutes in India and abroad that offer such training.

3. Mountain climbers are unanimous in agreeing that the unpredictable weather is what they fear the most. There may be sunshine one moment and a snowstorm the other. At higher altitudes, snow is a regular feature and being decisive about setting up camps or proceeding further is crucial. The icy sheets after ice storms make walking treacherous, while the powdery snow makes a mountaineer sink deep into the snow. Up there, where the intention is to embrace Nature's wonder, one realises that it cannot be done without facing its formidable glory. A true mountaineer may challenge the mountain, yet is always respectful to the powerful forces of nature.

4. Summiting mountains carries its own health risks such as oxygen and altitude sickness problems, frost bites, swelling of hands and feet, fluid collection in brain or lungs and exhaustion. Yet, the gratification mountaineers feel from mastering something that is so frightening, urges them to undertake these endeavours. We may think that the mountaineers are fearless, experts say, "Not at all. It's fear that keeps them so intrigued with such arduous journeys." Impulse and brazenness can be deadly foes. In the words of the Indian mountaineer, Bachendri Pal, "The biggest risk ... is to not to take the risk at all. Remember that."

**Based on your understanding of the passage, answer the questions given below.**

(a) Why does the writer say that mountains inspire 'awe' in humans? (Paragraph 1)

- (i) They present us with opportunities for exciting sports.
- (ii) They evoke the wish in us, to master them.
- (iii) They inspire in us, deeds of valour.
- (iv) They represent peace and calm, to us.

(b) Select the option that corresponds to the following relation below:

The more incredible the mountains—the greater the thrill (Paragraph 1)

- (i) The higher the stamina—the lower the food intake
- (ii) The more you laugh—the lesser your illness
- (iii) The smaller the car—the bigger the advantage

(iv) The heavier the luggage—the higher the penalty

(c) Select the option that displays what the writer projects, with reference to the following:

*So, mountain climbing is undoubtedly one of the most popular adventure sports*  
(Paragraph 1)

(i) Doubt                      (ii) caution                      (iii) conviction                      (iv) denial

(d) Complete the following with a phrase from paragraph 1.

Opinion	Reason
_____	Best experienced rather than described

(e) The writer compares training to penance in the line --*Then comes the penance of their rigorous training.*

(Paragraph 2)

State 1 point of similarity between training and penance.

(f) Based on your reading of the text, list 2 reasons why the writer says that “mountaineering is not a sport that can be embraced without preparation”. (Paragraph 2)

(g) What connect does the writer draw out between unpredictable weather and setting up of camps? (Paragraph 3)

(h) The writer says, “*A true mountaineer may challenge the mountain, yet is always respectful to the powerful forces of nature.*” (Paragraph 3)

Select the reason the mountaineer is respectful to the forces of nature, up in the mountains.

(i) Survival                      (ii) experience                      (iii) tradition                      (iv) directive

(i) Supply 1 point to justify the following:

*While mountain climbing, an impulsive mountaineer is either disaster-prone or as good as dead.*

(j) Evaluate the INAPPROPRIATE reason for the feeling of exhilaration on reaching a summit, that the mountain-climbers experience.

- (i) Achievement of a seemingly impossible feat
- (ii) Spectacular panoramic view
- (iii) Application of the inculcated survival instincts
- (iv) Opportunity to use sophisticated mountaineering equipment

## Q.2 Read the passage given below.

1. The North-East of India is a melting pot of variegated cultural mosaic of people and races, an ethnic tapestry of many hues and shades. Yet, these states are lesser explored as compared to the rest of the country. The new generations of travellers who are ‘money rich and time poor’ are increasingly looking for unique experiences --a phenomenon being called the emergence of the ‘experience economy’. For this new and growing breed of tourists, the North-East with its variety and uniqueness holds immense attraction.

2. A study conducted in 2020 by Dr. Sherap Bhutia, revealed that the foreign tourist arrival in the North-East increased from 37,380 persons in 2005 to 118,552 in 2014. The overall growth rate of tourist (both domestic and foreign) in the North-East was as high as 26.44% during 2005-06. A high and positive growth of 12.53% was registered in foreign tourist visits to North-East States of India during 2012 from 2011, which further rose to register a growth of 27.93% during 2013 from 2012. Foreign tourist arrivals in the North-East witnessed a growth of 39.77% during 2014 from 2013, according to data provided from the Ministry of Tourism, Government of India.

3. The study recommendations for tourism planners included the need to concentrate on some key areas like enhancement of tourist facilities, tourism financing, focus on community involvement and others for the

formulation of a sustainable tourism strategy in the North-East States of India.

(a) Infer one reason for the following, based on information in paragraph 1.

The rate of tourism in the North-East of India puzzles tourism officials.

(b) Select the appropriate option to fill in the blanks.

From paragraph 1, we can infer that the \_\_\_\_\_ and \_\_\_\_\_ of the North-Eastern states aid attracting the 'money rich and time poor' tourists.

- |                    |                    |              |            |
|--------------------|--------------------|--------------|------------|
| 1. Distinctiveness | 2. Conventionality | 3. diversity |            |
| 4. uniformity      | 5. modernity       |              |            |
| (i) 1 & 3          | (ii) 2 & 4         | (iii) 2 & 5  | (iv) 1 & 4 |

(c) Complete the following analogy correctly with a word/ phrase from paragraph 1:

aroma: cooking::\_\_\_\_: painting

(Clue: Just like aroma is integral to cooking, similarly is/ are integral to painting)

(d) Select the correct option to complete the following sentence:

Travellers advocating the 'experience economy' seek a holiday package with \_\_\_\_ (Paragraph 1)

- (i) grand facilities, expensive hotels and excellent services to pamper them.
- (ii) a wholesome experience within the budget they have planned for.
- (iii) places and cities to buy things from and opportunities spend money.
- (iv) cost-effective services, affordable accommodation and many days of touring.

(e) Select the chart that appropriately represents the trend of foreign tourist travels in the North-East, from 2011-2014, as per paragraph 2.

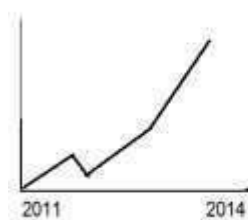

(1)

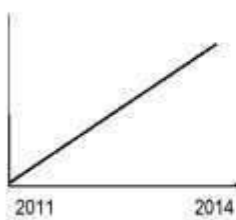

(2)

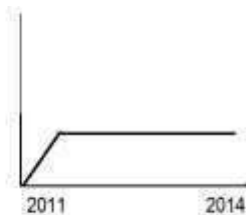

(3)

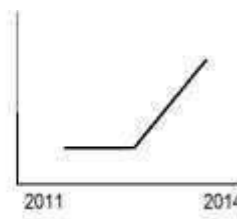

(4)

- (i) Option 1                      (ii) Option 2                      (iii) Option 3                      (iv) Option 4

(f) Fill in the blank by selecting the correct option.

The study of tourist travel statistics in the North-East, from 2005 to 2014 showed \_\_\_\_\_ results.

- (i) Expected                      (ii) encouraging                      (iii) inconsistent                      (iv) questionable

(g) Substitute the word 'witnessed' with ONE WORD similar in meaning, in the following, sentence from paragraph 2:

Foreign tourist arrivals in the North-East witnessed a growth of...

(h) List any 2 examples of 'tourist facilities' as referred to, in Paragraph 3.

(i) List one reason why the researchers recommend that the formulation of a tourism strategy in the North-Eastern States of India be sustainable.

(j) Select the option that titles paragraphs 1-3 appropriately, with reference to information in the text.

- |                     |                     |                          |                    |
|---------------------|---------------------|--------------------------|--------------------|
| 1 Full Speed Ahead! | 1 Winds of Change   | 1 Inspecting Trends      | 1 Cause & Effect   |
| 2 Ups and Downs     | 2 Numbers Don't Lie | 2 Statistically Speaking | 2 Dynamic Data     |
| 3 Cause for Concern | 3 Time for Action   | 3 Let's Investigate      | 3 Dependable Facts |

(A)

(B)

(C)

(D)

**SECTION-B (GRAMMAR & WRITING SKILLS)**

**Q.3 Attempt ANY TEN of the following questions:**

- (a) Fill in the blank by choosing the correct option to complete an online update.

The climate control comment by an activist\_\_\_on social media yesterday.

- (i) blow up                      (ii) blew up                      (iii) is blown                      (iv) will be blown

- (b) Read the conversation between a doctor and his patient. Complete the sentence by reporting the patient’s reply correctly.

Doctor: Do you feel down from time-to-time Mr. Gopalan? Patient: Yes, I do not stay in a good mood.

The doctor, while trying to figure out his patient’s ailment, asked about his well-being, to which, the patient affirmed \_\_\_\_\_.

- (c) Select the correct option to fill in the blank for the given line, from a health magazine.

The advertisement read, ‘If you smoke, statistically your story\_\_end 15% before it should’.

- (i) Must                      (ii) should                      (iii) will                      (iv) ought to

- (d) Select the option that identifies the error and supplies the correction for the following line, from a news report:

Last week a child was not allowed to board the plane at Ranchi airport.

error	correction

- (e) Complete the given narrative, by filling in the blank with the correct option:

As I was standing on the dock, looking out at the lake for the last time, a feeling of emptiness\_\_\_over me like darkness.

- (i) will wash                      (ii) had washed                      (iii) will have washed                      (iv) washed

- (f) Fill in the blank by using the correct form of the word in the bracket, for the given portion of a letter:

Subject: Request for Approval

Dear Sir

This is to respectfully submit that I\_\_\_(seek) approval for organising a tree plantation drive to be undertaken by the club.

- (g) Report the dialogue between a grandson and his grandfather, by completing the sentence:

Grandson: Grandpa, who are your superheroes?

Grandpa: Anyone who shows kindness and compassion to others.

- (h) In response to the question about his superheroes, grandfather says that \_\_\_\_\_.

- (i) Identify the error in the given sentence, from a school magazine report and supply the correction.

In order to balancing the sentiments of the Eagles and the Hawks, the Student Council suggested a rematch between the teams.

Use the given format for your response.

Option no.	error	correction
A.	child	children
B.	last	previous
C.	the	a
D.	at	in

- (j) Sunil shared some information, with Tariq, about a holiday at sea. Report Tariq's question.

Did you enjoy travelling by sea?

- (k) Fill in the blank by choosing the correct option, to complete the slogan by the Ministry for Child Welfare.

\_\_\_ WE AFFORD TO NEGLECT CHILDREN? THINK TWICE!!

- (i) WILL                      (ii) MAY                      (iii) NEED                      (iv) CAN

- (l) Select the correct option to complete the narration of the dialogue between Latha and her father.

Father: Why ask so many questions, Latha?

Latha: I believe that if you don't know the answer, keep asking till you do!

Father asked Latha the reason for the many questions she was asking. Latha exclaimed good-humouredly that in event of not knowing the answer one should

- (i) keep asking till one does.                      (ii) kept asking till one does.  
(iii) keep asking till one do.                      (iv) kept on to ask till one do.

- (m) Identify the error on a shop's hoarding and supply the correction, for the following sales offer:

Gumnaam & Daughters Pvt. Ltd.      Bindapur, Jharkhand

Massive discount for all senior citizen vaccinated with the precautionary dose.

Use the given format for your response.

**Q.4. Attempt ANY ONE from A and B given below.**

- A.** You are Sunidhi Prakash, the Vice Captain of Brilliant Vidyalaya, Barra, Kanpur. You have recently noticed several posters around your school premises conveying a hazardous message:

***Lose weight in just a month!***

*“A WONDER DIET comes to your rescue ...A privilege available for only a few!”*

Write a letter to the Editor of The DWA, in not more than 120 words, drawing attention towards harm caused by such advertising. Propose the implementation of ‘Wholesome Lunch Month’ in schools as an idea to address such practices, mention the advantages and share suggestions to foster healthy eating routines and develop positive body image among youngsters.

**OR**

- B.** You are Zac Skaria, a resident of # 412, Magna Greens Apartments, Gandhi Marg, Jonpara, Mumbai. Three students of grade 10 from your residential complex have rescued and rehabilitated a few old beggars from the neighbourhood. You think that their work deserves appreciation and recognition. Write a letter to the President of the RWA, seeking recommendation for these youth, to be nominated for ‘Serving Citizens’ Award’. Suggest other ways such acts of kindness could be recognised and awarded in the future.

**Q.5 Attempt ANY ONE from A and B given below.**

- A.** Gurmeet Kaur is an aspiring candidate for a public-funded engineering college in the suburbs. She belongs to a nearby village, has minimal technological skills and exposure, has the required cut-off percentage and is looking for a complete or partial scholarship.

Write a paragraph in about 100-120 words, analysing her SWOT notes to support your stand on whether she should join/not join the college.

<p style="text-align: center;"><b>STRENGTH</b></p> <ul style="list-style-type: none"><li>▪ Strong Curriculum</li><li>▪ Quality faculty</li><li>▪ Vibrant Activity Clubs</li><li>▪ Green location</li><li>▪ Close proximity to residential areas</li></ul> <table border="1" style="margin-left: auto; margin-right: auto;"><tr><td style="padding: 2px;">error</td><td style="padding: 2px;">correction</td></tr><tr><td style="padding: 2px;"> </td><td style="padding: 2px;"> </td></tr></table>	error	correction			<p style="text-align: center;"><b>WEAKNESS</b></p> <ul style="list-style-type: none"><li>▪ Lack of diversity</li><li>▪ Students’ behavioural problems</li><li>▪ No hostel facility</li><li>▪ Slow repair and maintenance work</li><li>▪ Underutilization of IT Services</li><li>▪ Lack of targeted advertisements to out-state students</li></ul>
error	correction				
<p style="text-align: center;"><b>OPPORTUNITIES</b></p> <ul style="list-style-type: none"><li>▪ Practice based research</li><li>▪ Partnership with professional organisations</li><li>▪ Strong alumni</li><li>▪ Acclaimed Student Exchange Programme with European countries</li></ul>	<p style="text-align: center;"><b>THREAT</b></p> <ul style="list-style-type: none"><li>▪ Lack of publicity in areas of excellence</li><li>▪ Public perception towards funded colleges</li><li>▪ Declining students’ interest towards technical subjects</li><li>▪ Low employee morale due to budget cuts</li></ul>				

**OR**

- B.** Read the following excerpt from an online post of a website on educational practices.

*Kids who appreciate how much effort, time and care goes into growing food will understand how important farmers are, and why it's important to take care of our Earth. In the world of today, gardening needs to be given more importance than sports, music and dance in all schools because it creates environmental stewards and outdoor learning laboratories that help the child and community for years to come.*

Write a paragraph in 100-120 words to analyse the given argument.

You could think about what alternative explanations might weaken the given conclusion and include rationale / evidence that would strengthen / counter the given argument.



### SECTION-C (LITERATURE)

#### **Q.6 Reference to the Context:**

##### **A. Attempt ANY ONE of two extracts given.**

*“Hey, a tea garden!” Rajvir cried excitedly.*

*Pranjol, who had been born and brought up on a plantation, didn't share Rajvir's excitement.*

*“Oh, this is tea country now,” he said. “Assam has the largest concentration of plantations in the world.*

*You will see enough gardens to last you a lifetime!”*

*“I have been reading as much as I could about tea,” Rajvir said. “No one really knows who discovered tea but there are many legends.” (Glimpses of India)*

- (a) Why was Pranjol not as excited as Rajvir about the tea gardens?
- (i) He disliked looking at tea gardens.
  - (ii) He had worked in tea gardens himself.
  - (iii) He had grown up in and around tea gardens.
  - (iv) He was bored with tea gardens.
- (b) What does Pranjol mean by saying that Assam has the largest concentration of plantations in the world?
- (c) Fill in the blank with ONE WORD only.

Pranjol's \_\_\_\_ comes through clearly when he exclaims, “You will see enough gardens to last you a lifetime!”

- (d) How according to Rajvir does the world know about the discovery of tea?
- (i) Historical places
  - (ii) Traditional tales
  - (iii) Authentic anecdotes
  - (iv) Popular publications
- (e) Select the option that correctly captures the application of the word ‘cried’ as used in line 1 of the extract.
- (i) Jaspreet cried a lot in spite of winning second place in a competition.
  - (ii) Jaspreet cried out loud when she saw a white tiger in the sanctuary.
  - (iii) Jaspreet cried for hours when the police were unable to find her lost pet.

(iv) Jaspreet has barely cried since she was three years of age.

**OR**

**B.** OMEGA: It shall be done, Sir. Remove vitamins. (Crew takes vitamins from boxes on their belts.) Present vitamins.

(They hold vitamins out in front of them, stiffly.) Swallow vitamins. (They pop the vitamins into their mouths and gulp simultaneously. They open their eyes wide, their heads shake, and they put their hands to their foreheads.)

THINK-TANK: Excellent. Now, decipher that code.

ALL: It shall be done, Sir. (They frown over the book, turning pages.) OMEGA: (brightly) Aha!

IOTA: (brightly) Oho!

OOP: (bursting into laughter) Ha, ha, ha.

THINK-TANK: What does it say? Tell me this instant. Transcribe, Omega.

*(The Book that Saved the Earth)*

(a) Select the option that correctly captures the usage of the word 'present' from line 1 of the extract.

(i) Oops received a nice present from Think Tank.

(ii) Iota needs to present his opinion firmly.

(iii) Omega must focus on the present and leave the past behind.

(iv) Oops didn't know anyone even though a crowd was present.

(b) Complete the analogy by selecting the suitable word from the text

frown: smile:: gloomily: \_\_\_\_\_

(c) Select the option that displays the reason why all crew members were asked to have vitamins.

In order to –

(i) boost their physical energies.

(ii) adapt to their circumstances.

(iii) quickly turn all the pages.

(iv) accomplish a specific task.

(d) According to the extract, what did THINK-TANK most likely want OMEGA to do when he said 'Transcribe...?'

1. read aloud

2. Translate

3. make notes

4. interpret

5. record reactions

Select the correct option.

(i) 1 & 3

(ii) 2 & 4

(iii) Only 3

(iv) 1, 4 and 5

(e) The playwright places certain words and sentences in brackets in the given extract. List any ways these benefit both the director and actors.

i) \_\_\_\_\_

ii) \_\_\_\_\_

**Q.7 Attempt ANY ONE of two extracts given.**

**A.** *The trees inside are moving out into the forest,  
the forest that was empty all these days  
where no bird could sit no insect hide*

*no sun bury its feet in shadow the forest that was empty all these nights  
will be full of trees by morning.*

*(The Trees)*

(a) Complete the sentence appropriately.

It is clear that Personification is the poetic device used for 'No sun bury its feet....' because \_\_\_\_\_. (*Clue: explain how personification applies here*)

(b) The poet has used a poetic device in the given lines. What effect does she wish to create by its use?

*...no bird could sit no insect hide*

*no sun...*

(i) emphasis            (ii) comparison            (iii) rhyme            (iv) humour

(c) State whether the following statement is TRUE or FALSE:

The extract uses trees as a symbol for conservative people.

(d) Select the appropriate option to complete the sentence, according to the extract. The idea of a forest that has been 'empty all these days' is\_\_.

(i) unnatural            (ii) scary            (iii) magical            (iv) legendary

(e) How does the use of enjambment impact this extract?

(i) It forces frequent pauses.            (ii) It simplifies the meaning.  
(iii) It builds momentum.            (iv) It makes the lines lyrical.

**OR**

**B.** *But I can get a hair-dye And  
set such colour there, Brown,  
or black, or carrot, That young  
men in despair  
May love me for myself alone  
And not my yellow hair."*  
*(For Anne Gregory)*

(a) What is the poet's tone in the extract?

1. Thoughtful            2. Authoritative            3. agitated  
4. insulting            5. argumentative

Select the appropriate option.

(i) 1, 4            (ii) 3, 5            (iii) 2, 4            (iv) 1, 5

(b) What causes the young men to 'despair', according to the extract?

(c) Identify the reason for the speaker's need to colour her hair, as per the extract.

(i) Her control over what makes her look beautiful.

- (ii) Her desire to be loved for inner beauty
  - (iii) Her need to change people's perception about beauty
  - (iv) Her conviction that she is beautiful inside
- (d) Complete the analogy about the speaker's hair. yellow: blonde :: \_\_\_\_\_: carrot
- (e) Select the sentence in which the word 'set' is used in the similar manner as line 2 of the extract.
- (i) I want to set him up and get my work done this time.
  - (ii) Do you have another set of the books that I can read?
  - (iii) The dessert needs to set for two hours before being served.
  - (iv) The set for the school play looked quite grand.

**Q.8 Answer ANY FOUR of the following in about 40-50 words each.**

- (a) Validate the given statement with reference to baby seagull's fear. 'Fear doesn't exist anywhere else other than one's mind.' (*His First Flight- Two Stories about Flying*)
- (b) Explain why the poet personally holds the conviction that the world will primarily end in fire? (*Fire and Ice*)
- (c) Valli's unique maiden bus ride experience could be possible because she belonged to a small village. Do you agree? Why? /Why not? (2 reasons) (*Madam Rides a Bus*)
- (d) Give one reason why 'The Tale of Custard the Dragon' is more a fable than a ballad.
- (e) How can we say that Natalya was continuously successful in maintaining an upper hand during her arguments with Lomov? (Any one example) (*The Proposal*)

**Q.9 Answer ANY TWO of the following in about 40-50 words each.**

- (a) Dr. Herriot knew his patients as well as their owners really well. Discuss. (*The Triumph of Surgery*)
- (b) State one likely reason the writer of *The Midnight Visitor* chose to characterise Ausable as short and fat.
- (c) Validate the importance of small, fun learning tasks towards successful careers, in the context of Richard Ebright in *The Making of a Scientist*.

**Q.10. Answer ANY ONE of the following in about 100-120 words.**

- (a) Mijbil and the Tiger, both were looked after by humans. Assume they both meet each other in the zoo and have a conversation about their lifestyle and feelings.

Write this conversation as per your understanding of Mijbil the Otter and A Tiger in the Zoo.

*You may begin like this*

*Tiger: Thanks for visiting me, though I don't usually like visitors.*

*Mijbil: Oh? I would love visitors, I think.*

**OR**

- (b) "Not from weeping nor from grieving will anyone obtain peace of mind".

If you had to use the message of the given quote from the Buddha's sermon (*The Sermon at Benares*) to help the boy cope with the loss of his ball and what it signifies (*The Ball Poem*), what would you include in your advice?

Also, evaluate why it might be difficult for him to understand the notion.

**Q.11. Answer ANY ONE of the following in about 100-120 words.**

(a) Fiction writers prefer creating grey characters rather than black and white. Analyse this in detail, with reference to both the characters of *The Thief's Story*

OR

(b) 'Honour among thieves' is considered a popular code.

Examine *A Question of Trust* as a story woven around this code.

## हिंदी

1. इस प्रश्न पत्र में चार खंड हैं क, ख, ग और प
2. खंड क में अपठित गद्यांश से प्रश्न पूछे गए हैं, जिनके उत्तर दिए गए निर्देशों का पालन करते हुए दीजिए।
3. खंड ख में व्यावहारिक व्याकरण से प्रश्न पूछे गए हैं, आंतरिक विकल्प भी दिए गए हैं।
4. खंड ग पाठ्यपुस्तक पर आधारित है, निर्देशानुसार उत्तर दीजिए।
5. खंड प रचनात्मक लेखन पर आधारित है आंतरिक विकल्प भी दिए गए हैं।
6. प्रश्नपत्र में कुल 16 प्रश्न हैं, सभी प्रश्न अनिवार्य हैं।
7. यथा संभव सभी खंडों के प्रश्नों के उत्तर क्रमशः लिखिए।

### खंड 'क' (अपठित बोध)

**1. निम्नलिखित गद्यांश को ध्यानपूर्वक पढ़कर पूछे गए प्रश्नों के उत्तर लिखिए-**

वर्तमान युग कंप्यूटर का युग है। यदि भारतवर्ष पर नज़र दौड़ाकर देखें, तो हम पाएँगे कि जीवन के लगभग सभी क्षेत्रों में कंप्यूटर का प्रवेश हो गया है। बैंक, रेलवे स्टेशन, हवाई अड्डे, डाकखाने, बड़े-बड़े उद्योग-कारखाने, व्यवसाय, हिसाब-किताब, रुपये गिनने तक की मशीनें कंप्यूटरीकृत हो गई हैं। जब भी यह कंप्यूटर का प्रारंभिक प्रयोग है। आने वाला समय इसके विस्तृत फैलाव का संकेत दे रहा है। प्रश्न उठता है कि क्या कंप्यूटर आज की ज़रूरत है? इसका उत्तर है- कंप्यूटर जीवन की मूलभूत अनिवार्य वस्तु तो नहीं है, किंतु इसके बिना आज की दुनिया अधूरी जान पड़ती है। सांसारिक गतिविधियों, परिवहन और संचार उपकरणों आदि का ऐसा विस्तार हो गया है कि उन्हें सुचारु रूप से चताना अत्यंत कठिन होता जा रहा है।

पहले मनुष्य जीवनभर में अगर सी लोगों के संपर्क में आता था, तो आज वह दो-हजार लोगों के संपर्क में आता है। पहले दिन में पाँच-दस लोगों से मिलता था, तो आज पचास-सी लोगों से मिलता है। पहले वह दिन में काम करता था, तो आज रातें भी व्यस्त रहती हैं। आज व्यक्ति के संपर्क बढ़ रहे हैं, व्यापार बढ़ रहे हैं, गतिविधियाँ बढ़ रही हैं, आकांक्षाएँ बढ़ रही हैं, साधन बढ़ रहे हैं। इस अनियंत्रित गति को सुव्यवस्था देने की समस्या आज की प्रमुख समस्या है। कहते हैं आवश्यकता आविष्कार की जननी है। इस आवश्यकता ने अपने अनुसार निदान ढूँढ़ लिया है। कंप्यूटर एक ऐसी स्वचालित प्रणाली है, जो किसी भी अव्यवस्था को व्यवस्था में बदल सकती है। हड़बड़ी में होने वाली मानवीय भूलों के लिए कंप्यूटर रामबाण औषधि है। क्रिकेट के मैदान में अंपायर की निर्णायक भूमिका हो या लाखों-करोड़ों की लंबी-लंबी गणनाएँ कंप्यूटर पलक झपकते ही आपकी समस्या हल कर सकता है। पहले इन कामों को करने वाले कर्मचारी हड़बड़ाकर काम करते थे, एक भूल से घबराकर और अधिक गड़बड़ी करते थे। परिणामस्वरूप काम कम, तनाव अधिक होता था। अब कंप्यूटर की सहायता से काफी सुविधा हो गई है।

(1) कंप्यूटर के बिना आज की दुनिया अपूर्ण है, क्योंकि-

- (क) सारी व्यवस्था, उपकरण और मशीनें कंप्यूटरीकृत हैं। (ख) कंप्यूटर ही मानव एकीकरण का आधार है।  
(ग) कंप्यूटर ने सारी प्रक्रियाएँ आसान बना दी हैं। (घ) कंप्यूटर द्वारा मानव सभ्यता अधिक समर्थ हो गई है।

(4) वर्तमान युग कंप्यूटर का युग है क्योंकि:-

- (क) कंप्यूटर के बिना जीवन की कल्पना असंभव हो गई है। (ख) कंप्यूटर ने पूरे विश्व के लोगों को जोड़ दिया है।  
(ग) कंप्यूटर जीवन की अनिवार्य मूलभूत वस्तु बन गया है।  
(घ) कंप्यूटर मानव सभ्यता के सभी अंगों का अभिन्न अवयव बन चुका है।

(iii) निम्नलिखित कथन और निष्कर्ष को ध्यान से पढ़कर दिए गए विकल्प से सही उत्तर चुनकर लिखिए-

कथन: हड़बड़ी में होने वाली मानवीय भूलों के लिए कंप्यूटर रामबाण औषधि है।

निष्कर्ष: वर्तमान युग में कंप्यूटर मानव जीवन का अभिन्न अंग बन गया है।

(क) कथन सही है लेकिन निष्कर्ष गलत है।

(ख) कथन और निष्कर्ष दोनों सही हैं।

(ग) कथन गलत है और निष्कर्ष सही है।

(घ) कथन और निष्कर्ष दोनों गलत हैं।

(iv) 'स्वचालित प्रणाली' से लेखक का क्या तात्पर्य है?

(v) गद्यांश हमें क्या संदेश देता है?

2. निम्नलिखित गद्यांश को ध्यानपूर्वक पढ़कर पूछे गए प्रश्नों के उत्तर लिखिए।

पशु को बाँधकर रखना पड़ता है, क्योंकि वह निरंकुश है। चाहे जहाँ-तहाँ चला जाता है, इधर-उधर मुँह मार देता है। क्या मनुष्य को भी इसी प्रकार दूसरों का बंधन स्वीकार करना चाहिए? क्या इससे उसमें मनुष्यत्व रह जाएगा। पशु के गले की रस्सी को एक हाथ में पकड़कर और दूसरे हाथ में एक लकड़ी लेकर जहाँ चाहे हाँककर ले जाओ। जिन लोगों को इसी प्रकार हाँकेजाने जाने का स्वभाव पड़ गया है, जिन्हें कोई भी जिधर चाहे ले जा सकता है, काम में लगा सकता है, उन्हें भी पशु ही कहा जाएगा। पशु को चाहे कितना मारो, चाहे कितना उसका अपमान करो, बाद में खाने को दे दो, वह पूँछ और कान हिलाने लगेगा। ऐसे नर पशु भी बहुत से मिलेंगे जो कुचले जाने और अपमानित होने पर भी जरा-सी वस्तु मिलने पर झट संतुष्ट और प्रसन्न हो जाते हैं। पशु को कितना ही ताड़ना देने के बाद उसके सामने एक टुकड़ा डाल दो, वह झट से मार-पीट को भूलकर उसे खाने लगेगा। यदि हम भी ऐसे ही हैं, तो हम कौन हैं, इसे स्पष्ट कहने की आवश्यकता नहीं। पशुओं में भी कई पशु मार-पीट और अपमान को नहीं सहते। वे कई दिन तक निराहार रहते हैं, कई पशुओं ने तो प्राण त्याग दिए, ऐसा सुना जाता है। पर इस प्रकार के पशु मनुष्य-कोटि के हैं, उनमें मनुष्यत्व का समावेश है, यदि ऐसा कहा जाए तो कोई अत्युक्ति न होगी।

(1) गद्यांश में मनुष्य और पशु की तुलना का आधार बताया गया है-

- (क) पिटने की क्षमता (ख) हाथ-पैर आदि को हिलाना  
(ग) बंधन स्वीकार करना (घ) लकड़ी द्वारा हाँके जाना

(2) निम्नलिखित में से कौन-सा शब्द गद्यांश में दिए गए 'निराहार' शब्द के सही अर्थ को दर्शाता है?

- (क) उपवास (ख) भोजन  
(ग) जल (घ) फल सेवन

(iii) निम्नलिखित कथन (A) तथा कारण (R) को ध्यानपूर्वक पढ़िए। उसके बाद दिए गए विकल्पों में से कोई एक सही विकल्प चुनकर लिखिए।

कथन (A): कई पशु अपमान नहीं सहते।

कारण (R): अपमान न सहने वाले पशु मनुष्य कोटि में आते हैं।

(क) कथन (A) सही है, कारण (R) गलत है।

(ख) कथन (A) तथा कारण (R) दोनों गलत हैं।

(ग) कथन (A) सही है, और कारण (R) उसकी सही व्याख्या है।

(घ) कथन (A) गलत है किन्तु कारण (R) सही है।

- (iv) बंधन स्वीकार करने से मनुष्य पर क्या प्रभाव पड़ेगा?  
 (v) किस प्रकार के पशुओं में मनुष्यत्व का समावेश होता है?

3. 'पदबंध' पर आधारित पाँच प्रश्नों में से किन्हीं चार प्रश्नों के उत्तर लिखिए-

किसी वाक्य में विशेषण पदबंध की पहचान कैसे की जाती है, उदाहरण देकर स्पष्ट कीजिए।

अकसर हम गुजरे हुए दिनों की खट्टी-मीठी यादों में उलझे रहते हैं। वाक्य में पदबंध का भेद बताते हुए कारण भी स्पष्ट कीजिए।

(iii) सर्वनाम पदबंध का एक उदाहरण देकर वाक्य में प्रयोग कीजिए।

- (i) अब भाई साहब नरम पड़ गए थे। वाक्य में रेखांकित पदबंध का भेद लिखिए।  
 (ii) मैं तेजी से दौड़ता हुआ हॉस्टल पहुँचा। वाक्य में से क्रियाविशेषण पदबंध चुनकर लिखिए।

4. 'रचना के आधार पर वाक्य रूपांतरण' पर आधारित पाँच प्रश्नों में से किन्हीं चार प्रश्नों के उत्तर लिखिए-

- (i) ग्वालियर में हमारे एक मकान के दालान में दो रोशनदान थे। संयुक्त वाक्य में रूपांतरित कीजिए।  
 (ii) हमें अच्छी तरह मालूम है कि वह इन्हीं जंगलों में है। वाक्य का भेद बताते हुए कारण स्पष्ट कीजिए।  
 (iii) भाई साहब ने अधिक परिश्रम किया था इसलिए उनकी मुद्रा कांतीहीन हो गई थी। वाक्य का भेद लिखिए।  
 (iv) जीवन में यह पहली बार है कि मैं इस तरह विचलित हुआ हूँ। सरल वाक्य में रूपांतरित कीजिए।

(v) उदाहरण द्वारा मिश्रित वाक्य एवं संयुक्त वाक्य में अंतर स्पष्ट कीजिए।

5. 'समास' पर आधारित पाँच प्रश्नों में से किन्हीं चार प्रश्नों के उत्तर लिखिए-

- (i) 'पीतांबर' बहुव्रीहि समास है कैसे?  
 (ii) द्वंद्व समास की विशेषता बताते हुए एक उदाहरण दीजिए।  
 (क) तत्पुरुष समास में उत्तरपद की भूमिका स्पष्ट कीजिए।  
 (iv) 'आजन्म' सामासिक पद का विग्रह करते हुए भेद लिखिए।  
 (v) 'पंचरत्न' सामासिक पद का विग्रह करते हुए भेद लिखिए।

6. 'मुहावरे' पर आधारित पाँच प्रश्नों में से किन्हीं चार प्रश्नों के उत्तर लिखिए-

- (i) पढ़ाई में मेहनत कर मैं .... हो सकता हूँ। रिक्त स्थान की पूर्ति उचित मुहावरे से कीजिए।  
 (ii) सच्चे देशभक्त देश की रक्षा में प्राणों की.... कीजिए देते हैं। रिक्त स्थान की पूर्ति उचित मुहावरे से  
 (iii) वामीरो की माँ ने ततारा को तरह-तरह से अपमानित किया। गाँव के लोग भी ततारा के विरोध में आवाजें उठाने लगे। पंक्ति से मुहावरा चुनकर वाक्य में प्रयोग कीजिए।

(iv) 'ठंडी पड़ना' मुहावरे का वाक्य बनाइए।

(v) 'आँखें फोड़ना' और 'आँखों में धूल झोंकना' मुहावरे में अंतर स्पष्ट कीजिए।

खंड-'ग' (पाठ्यपुस्तक एवं पूरक पाठ्यपुस्तक)

7. निम्नलिखित गद्यांश को पढ़कर पूछे गए प्रश्नों के उत्तर के लिए सही विकल्प का चयन कीजिए-

हमारे जीवन की रफ्तार बढ़ गई है। यहाँ कोई चलता नहीं, बल्कि दौड़ता है। कोई बोलता नहीं, बकता है। हम जब अकेले पड़ते हैं, तब अपने आपसे लगातार बड़बड़ाते रहते हैं। अमेरिका से हम प्रतिस्पर्धा करने लगे। एक महीने में पूरा होने वाला काम एक दिन में पूरा करने की कोशिश करने लगे। वैसे भी दिमाग की रफ्तार हमेशा तेज ही रहती है। उसे 'स्पीड' का इंजन लगाने पर वह हजार गुना अधिक रफ्तार से दौड़ने लगता है। फिर एक क्षण ऐसा आता है जब दिमाग का तनाव बढ़ जाता है और पूरा इंजन टूट जाता है। यही कारण है जिससे मानसिक रोग यहाँ बढ़ गए हैं।

अकसर हम या तो गुजरे हुए दिनों की खट्टी-मीठी यादों में उलझे रहते हैं या भविष्य के रंगीन सपने देखते रहते हैं। हम या तो भूतकाल में रहते हैं या भविष्यकाल में। असल में दोनों ही काल मिथ्या हैं। एक चला गया है, दूसरा आया नहीं है। हमारे सामने जो वर्तमान धन है, वही सत्य है। उसी में जीना चाहिए। चाय पीते-पीते उस दिन दिमाग से भूत और भविष्य दोनों काल उड़ गए थे। केवल वर्तमान क्षण सामने था और वह अनंतकाल जितना विस्तृत था।

(i) गद्यांश में मानसिक रोगों के बढ़ने का क्या कारण बताया गया है?

- (क) अमेरिका से प्रतिस्पर्धा करना। (ख) सामर्थ्य से अधिक कार्य करने का दबाव।

(ग) भूतकाल के बारे में सोचना।

(घ) खट्टी-मीठी यादों में उलझे रहना।

(ii) जीवन की रफ्तार बढ़ने का क्या अर्थ है?

(क) प्रतियोगी होना।

(ख) तीव्र गति से कार्य का निष्पादन करना।

(ग) दूसरों को हराना।

(घ) जल्दी बूढ़ा होना।

(iii) 'दोनों ही काल मिथ्या है' इसका क्या तात्पर्य है?

(क) समय सदा सत्य नहीं रहता।

(ख) भूतकाल और भविष्यत् काल दोनों ही काल झूठे हैं।

(ग) व्यक्ति का नियंत्रण केवल वर्तमान पर रहता है।

(घ) वर्तमान काल और भविष्यत् काल मिथ्या हैं।

(iv) निम्नलिखित कथन (A) तथा कारण (R) को पढ़कर उचित विकल्प का चयन कीजिए।

कथन (A): हमें केवल वर्तमान में जीना चाहिए।

कारण (R): हमारे सामने जो वर्तमान क्षण होता है। वह वर्तमान क्षण ही सत्य है।

(क) कथन (A) तथा कारण (R) दोनों गलत हैं।

(ख) कथन (A) तथा कारण (R) दोनों सही हैं।

(ग) कथन (A) गलत है तथा कारण (R) सही है।

(घ) कथन (A) सही है लेकिन कारण (R) उसकी गलत व्याख्या करता है।

(v) लेखक के लिए अनंतकाल के विस्तृत होने का क्या कारण था?

(क) समय व्यतीत नहीं हो पाने के कारण।

(ख) लेखक के बोर होने के कारण।

(ग) लेखक केवल वर्तमान के बारे में ही सोच पा रहा था।

(घ) आकाश का दूसरा नाम अनंत है।

8. गद्य खंड पर आधारित निम्नलिखित प्रश्नों में से किन्हीं तीन प्रश्नों के उत्तर लगभग 25-30 शब्दों में दीजिए-

(i) ततारा-वामीरी की त्यागमयी मृत्यु से निकोबार में क्या परिवर्तन आया?

(ii) अंग्रेज़ हमारे देश में व्यापार करने आए थे। लेकिन वे हमारे देश के शासक बन बैठे थे। वे हमारे ऊपर अत्याचार करने लगे जिससे यहाँ की जनता ने उन्हें भगाना उचित समझा।

आपके द्वारा इस पाठ्यक्रम में पढ़े गए पाठ में लेखक ने अंग्रेज़ों के शासनकाल की एक झलक प्रस्तुत की है। जिसके प्रमुख पात्र वज़ीर अली के जीवन का लक्ष्य अंग्रेज़ों को इस देश से बाहर करना था। 'कारतूस' पाठ के आधार पर इस कथन की सत्यता सिद्ध कीजिए।

(iii) 'डायरी का एक पन्ना' पाठ के आधार पर बताइए कि पुलिस ने कैसा दमनचक्र चलाया और क्यों? लोगों ने किस प्रकार उसका मुंहतोड़ जवाब दिया?

(iv) इस वर्ष आपने पाठ्यक्रम में शाश्वत मूल्यों पर आधारित एक पाठ पढ़ा है। इस पाठ में बताया गया है कि गांधी जी में नेतृत्व की अद्भुत क्षमता थी। उदाहरण देकर इस बात की पुष्टि कीजिए।

9. निम्नलिखित पद्यांश को पढ़कर पूछे गए प्रश्नों के उत्तर के लिए सही विकल्प का चयन कीजिए-

कर चले हम फिदा जानो-तन साथियो

अब तुम्हारे हवाले वतन साथियो,

साँस यमती गई, नब्ज जमती गई

फिर भी बढ़ते कदम को न रुकने दिया,

कट गए सर हमारे तो कुछ गम नहीं

सर हिमालय का हमने न झुकने दिया,

मरते-मरते रहा बॉकपन साथियो

अब तुम्हारे हवाले वतन साथियो।

जिंदा रहने के मौसम बहुत हैं मगर

जान देने की रुत रोज आती नहीं,

हुस्न और इश्क दोनों को रुस्वा करे

वो जवानी जो हूँ मैं नहाती नहीं,

आज घरती बनी है दुल्हन साथियो

अब तुम्हारे हवाले वतन साथियो



(i) प्रस्तुत पंक्तियों में सैनिक मरते दम तक अपने देश के मान-सम्मान के लिए लड़ता रहता है। इन पंक्तियों के माध्यम से कवि देशवासियों को किस बात के लिए प्रेरित कर रहा है?

(क) राज्य प्रेम (ख) राष्ट्र प्रेम (ग) धर्म प्रेम (घ) संप्रदाय प्रेम

(ii) पद्यांश में 'बाँकपन' शब्द किसका प्रतीक है?

(क) वक्रता का (ख) अब्धुत सौंदर्य का (ग) सुंदर छवि का (घ) बेमिसालपन का

(iii) निम्नलिखित कवन (A) तथा कारण (R) को ध्यानपूर्वक पढ़िए। उसके बाद दिए गए विकल्प में से कोई एक सही विकल्प चुनकर लिखिए।

अभिकथन (A): सैनिकों ने देश की रक्षा के लिए अपना सिर तक कटा दिया परंतु भारत के गौरव हिमालय का सिर नहीं झुकने दिया।

कारण (R): सैनिकों के रक्त से आज सारी धरती दुलहन की तरह लाल रंग से भरी हुई है।

(क) कथन (A) गलत है, किंतु कारण (R) सही है।

(ख) कथन (A) और कारण (R) दोनों ही गलत हैं।

(ग) कथन (A) सही है और कारण (R) कथन (A) की सही व्याख्या है।

(घ) कथन (A) सही है किंतु कारण (R) कथन (A) की सही व्याख्या नहीं है।

(iv) 'सर पर कफ़न बाँधने' का क्या अर्थ है?

(क) बलिदान के लिए तैयार रहना।

(ख) मरने की कोशिश करना।

(ग) अपने लिए जान की बाजी लगाना।

(घ) लोगों को दिखाना कि हम मरने से नहीं डरते।

(v) उपर्युक्त पद्यांश के संबंध में कौन-सा कवन असत्य है?

(क) सैनिक मरते समय अपने देशवासियों को संबोधित कर रहा है।

(ख) सैनिक को जान देने का कोई गम नहीं है।

(ग) देशवासियों को केवल अपने घर की रक्षा करनी चाहिए।

(घ) धरती शहीदों के खून से लाल हो गई है।

10. काव्य खंड पर आधारित निम्नलिखित प्रश्नों में से किन्हीं तीन प्रश्नों के पलर लगभग 25-30 शब्दों में दीजिए-

(i) वर्षा ऋतु में पर्वतीय प्रदेश का प्राकृतिक दृश्य अत्यंत मनोरम हो जाता है। इस कथन के आलोक में पर्वत प्रदेश में पावस' कविता का प्रतिपाद्य अपने शब्दों में लिखिए।

(ii) कवि मैथिलीशरण गुप्त ने कहा, 'अतर्क एक पंथ के सतर्क पंथ ही सभी। इस पंक्ति की सार्थकता व वर्तमान समय में इसका औचित्य स्थापित कीजिए।

(iii) 'आत्मत्राण' शीर्षक का अर्थ बताते हुए उसकी सार्थकता, कविता के संदर्भ में स्पष्ट कीजिए।

(iv) मीरा भक्ति के विषय में क्या संदेश देना चाहती हैं?

11. पूरक पुस्तक 'संचवन' पर आधारित निम्नलिखित प्रश्नों में से किन्हीं दो प्रश्नों के उत्तर लगभग 50-60 शब्दों में दीजिए-

(i) .... तुम्हारे हिस्से में पंद्रह बीघे खेत हैं।... तुम अपने हिस्से का खेत ठाकुर जी के नाम लिख दो। 'हरिहर काका की पंद्रह बीघे ज़मीन उनके लिए जी का जंजाल बन गई।' कथन के आलोक में अपने विचार व्यक्त कीजिए।

(ii) लेखक गुरदयाल सिंह अपने छात्र जीवन में छुट्टियों के काम को पूरा करने के लिए योजनाएँ तैयार करते थे। क्या आपकी योजनाएँ लेखक की योजनाओं से मेल खाती हैं? उदाहरण देकर स्पष्ट कीजिए।

(iii) टोपी ज़हीन होने के बावजूद कक्षा में दो बार फेल हो गया। जीवन में प्रतिकूल परिस्थितियों से हार मान लेना कहीं तक उचित है? टोपी जैसे बच्चों के विषय में आपकी क्या राय है?

खंड 'घ' (रचनात्मक लेखन)

12. निम्नलिखित में से किसी एक विषय पर संकेत-बिंदुओं के आधार पर लगभग 120 शब्दों में अनुच्छेद लिखिए-

(i) जब हम चार रनों से पिछड़ रहे थे

संकेत-बिंदु

- खिलाड़ियों की मनोदशा
- दर्शकों की मनोदशा

● प्रयास और परिणाम  
(ii) देश पर पड़ता विदेशी प्रभाव  
संकेत-बिंदु

- हमारा देश और संस्कृति
- विदेशी प्रभाव
- परिणाम और सुझाव

(iii) मित्रता  
संकेत-बिंदु

- आवश्यकता
- सच्ची मित्रता का महत्व
- लाभ

**13. किसी एक विषय पर लगभग 100 शब्दों में पत्र लिखिए-**

आपसे अपने बचत खाते की चेक बुक खो गई है। इस संबंध में बैंक प्रबंधक को उचित कार्यवाही करने के लिए पत्र लिखिए।

**अथवा**

नगर निगम को एक पत्र लिखिए जिसमें नालियों की सफाई एवं कीटनाशक दवाओं के छिड़काव का सुझाव हो।

**14. निम्नलिखित में से किसी एक विषय पर लगभग 60 शब्दों में सूचना लिखिए-**

विद्यालय के वार्षिकोत्सव समारोह के आयोजन के लिए आपको संयोजक बनाया गया है। विद्यालय की ओर से सभी विद्यार्थियों के लिए एक सूचना तैयार कीजिए।

**अथवा**

विद्यालय में छुट्टी के उपरांत फुटबॉल सीखने के लिए विशेष कक्षाएँ आयोजित की जाएँगी। इच्छुक विद्यार्थियों द्वारा अपना नाम देने हेतु सूचना-पट्ट के लिए एक सूचना तैयार कीजिए।

**15. निम्नलिखित में से किसी एक विषय पर लगभग 40 शब्दों में विज्ञापन तैयार कीजिए-**

विद्यालय के 'अहंग समूह' द्वारा प्रस्तुत ताजमहल नाटक के बारे में नाम, पार, दिन, समय, टिकट आदि की सूचना देते हुए एक विज्ञापन तैयार कीजिए।

**अथवा**

अपनी दुकान को किराए पर उठाने के लिए एक विज्ञापन तैयार कीजिए।

**16. 'यदि मैं समाचार-पत्र होता, तो मैं भी सभी को देश-दुनिया की ताज़ी खबरों से अवगत कराता रहता..' से लगभग 100 शब्दों में लघुकथा लिखिए।**

**अथवा**

आपके विद्यालय में वार्षिक खेल दिवस मनाया गया। इसकी जानकारी देते हुए स्कूल प्रबंधन समिति के अध्यक्ष को 80 शब्दों में ई-मेल लिखिए।

## MATHEMATICS

### General Instructions:

- This Question Paper has 5 Sections A, B, C, D, and E.*
- Section A has 20 Multiple Choice Questions (MCQs) carrying 1 mark each.*
- Section B has 5 questions carrying 2 marks each.*
- Section C has 6 questions carrying 3 marks each.*
- Section D has 4 questions carrying 5 marks each.*

(vi) **Section E** has 3 sourced based/Case Based/passage based/integrated units of assessment (4 marks each) with sub-parts of the values of 1, 1 and 2 marks each respectively.

(vii) All Questions are compulsory. However, an internal choice in 2 Qs of 5 marks, 2 Qs of 3 marks and 2 Questions of 2 marks has been provided. An internal choice has been provided in the 2 marks questions of Section E.

(viii) Draw neat figures wherever required. Take  $\pi = 22/7$  wherever required if not stated.

### SECTION-A

Q.1 If two positive integers a and b are written as  $a = x^3y^2$  and  $b = xy^3$ , where x, y are prime numbers, then the result obtained by dividing the product of the positive integers by the LCM (a, b) is

(a)  $xy$

(b)  $xy^2$

(c)  $x^3y^3$

(d)  $x^2y^2$

Q.2 The given linear polynomial  $y = f(x)$  has

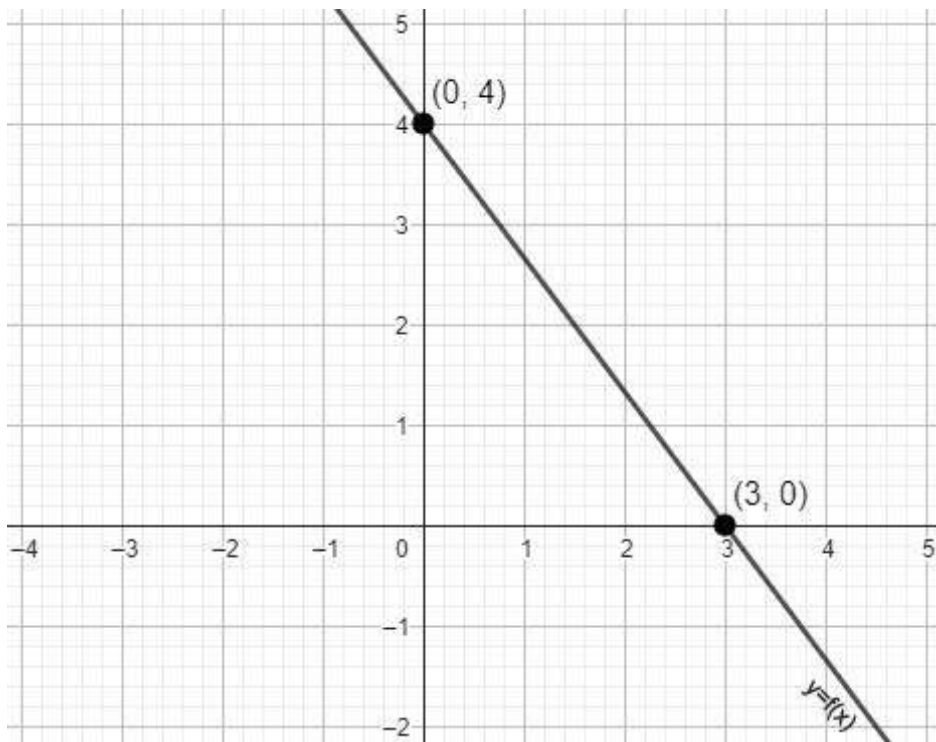

(a) 2 zeros

(b) 1 zero and the zero is '3'

(c) 1 zero and the zero is '4'

(d) No zero

Q.3 The lines representing the given pair of linear equations are non-intersecting. Which of the following statements is true?

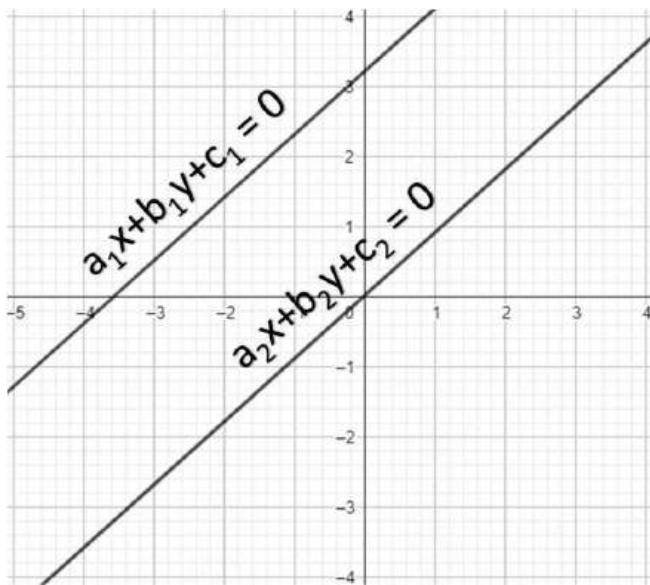

(a)  $\frac{a_1}{a_2} = \frac{b_1}{b_2} = \frac{c_1}{c_2}$

(b)  $\frac{a_1}{a_2} = \frac{b_1}{b_2} \neq \frac{c_1}{c_2}$

(c)  $\frac{a_1}{a_2} \neq \frac{b_1}{b_2} = \frac{c_1}{c_2}$

(d)  $\frac{a_1}{a_2} \neq \frac{b_1}{b_2} \neq \frac{c_1}{c_2}$

Q.4 The nature of roots of the quadratic equation  $9x^2 - 6x - 2 = 0$  is:

(a) No real roots

(b) 2 equal real roots

(c) 2 distinct real roots

(d) More than 2 real roots

Q.5 Two APs have the same common difference. The first term of one of these is  $-1$  and that of the other is  $-8$ .

The difference between their 4th terms is

(a) 1

(b) -7

(c) 7

(d) 9

Q.6 What is the ratio in which the line segment joining  $(2, -3)$  and  $(5, 6)$  is divided by x-axis?

(a) 1:2

(b) 2:1

(c) 2:5

(d) 5:2

Q.7 A point  $(x, y)$  is at a distance of 5 units from the origin. How many such points lie in the third quadrant?

(a) 0

(b) 1

(c) 2

(d) infinitely many

Q.8 In  $\triangle ABC$ ,  $DE \parallel AB$ . If  $AB = a$ ,  $DE = x$ ,  $BE = b$  and  $EC = c$ .

Then  $x$  expressed in terms of  $a$ ,  $b$  and  $c$  is:

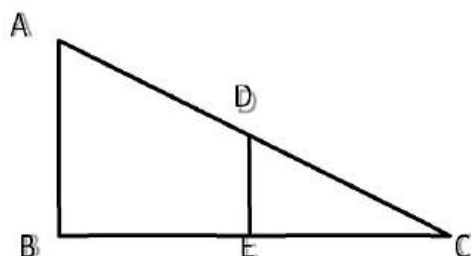

(a)  $\frac{ac}{b}$

(b)  $\frac{ac}{b+c}$

(c)  $\frac{ab}{c}$

(d)  $\frac{ab}{b+c}$

Q.9 If O is centre of a circle and Chord PQ makes an angle  $50^\circ$  with the tangent PR at the point of contact P, then the angle subtended by the chord at the centre is

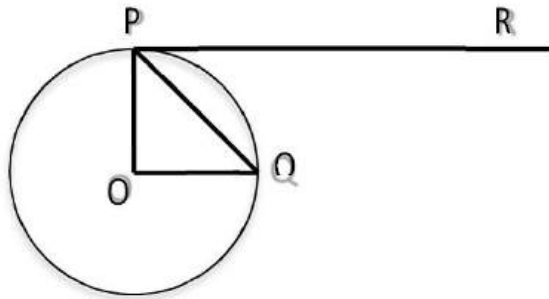

(a)  $130^\circ$

(b)  $100^\circ$

(c)  $50^\circ$

(d)  $30^\circ$

Q.10 A quadrilateral PQRS is drawn to circumscribe a circle.

If  $PQ = 12$  cm,  $QR = 15$  cm and  $RS = 14$  cm, then find the length of SP is

(a) 15 cm

(b) 14 cm

(c) 12 cm

(d) 11 cm

Q.11 Given that  $\theta = \frac{a}{b}$ , then  $\cos \theta$  is.

(a)  $\frac{b}{\sqrt{b^2 - a^2}}$

(b)  $\frac{b}{a}$

(c)  $\frac{\sqrt{b^2 - a^2}}{b}$

(d)  $\frac{a}{\sqrt{b^2 - a^2}}$

Q.12  $(\sec A + \tan A)(1 - \sin A)$  equals:

(a)  $\sec A$

(b)  $\sin A$

(c)  $\operatorname{cosec} A$

(d)  $\cos A$

Q.13 If a pole 6 m high casts a shadow  $2\sqrt{3}$  long on the ground, then the Sun's elevation is

(a)  $60^\circ$

(b)  $45^\circ$

(c)  $30^\circ$

(d)  $90^\circ$

Q.14 If the perimeter and the area of a circle are numerically equal, then the radius of the circle is

(a) 2 units

(b)  $\pi$  units

(c) 4 units

(d) 7 units

Q.15 It is proposed to build a new circular park equal in area to the sum of areas of two circular parks of diameters 16 m and 12 m in a locality. The radius of the new park is

(a) 10m

(b) 15m

(c) 20m

(d) 24m

Q.16 In an A.P.m if  $d = -4$ ,  $n = 7$ ,  $a_n = 4$ , then  $a$  is

- (a) 6 (b) 7 (c) 20 (d) 28

Q.17 If one zero of the polynomial  $x^2 - 3kx + 4k$  is twice the other, the value of  $k$  is

- (a) -2 (b) 2 (c)  $\frac{1}{2}$  (d)  $-\frac{1}{2}$

Q.18 The upper limit of the modal class of the given distribution is:

Height [in cm]	Below 140	Below 145	Below 150	Below 155	Below 160	Below 165
Number of girls	4	11	29	40	46	51

- (a) 165 (b) 160 (c) 155 (d) 150

Q.19 DIRECTION: In the question number 19 and 20, a statement of assertion (A) is followed by a statement of Reason (R). Choose the correct option

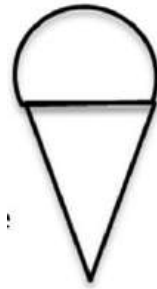

Statement A (Assertion): Total Surface area of the top is the sum of the curved surface area of the hemisphere and the curved surface area of the cone.

Statement R (Reason): Top is obtained by joining the plane surfaces of the hemisphere and cone together.

- (a) Both assertion (A) and reason (R) are true and reason (R) is the correct explanation of assertion (A).  
(b) Both assertion (A) and reason (R) are true but reason (R) is not the correct explanation of assertion (A).  
(c) Assertion (A) is true but reason (R) is false.  
(d) Assertion (A) is false but reason (R) is true.

Q.20 Statement A (Assertion):  $-5, \frac{-5}{2}, 0, \frac{5}{2}, \dots$  is in Arithmetic Progression.

Statement R (Reason): The terms of an Arithmetic Progression cannot have both positive and negative rational numbers.

- (a) Both assertion (A) and reason (R) are true and reason (R) is the correct explanation of assertion (A).  
(b) Both assertion (A) and reason (R) are true but reason (R) is not the correct explanation of assertion (A).

(c) Assertion (A) is true but reason (R) is false.

(d) Assertion (A) is false but reason (R) is true.

**SECTION-B**

Q.21 Prove that  $\sqrt{2}$  is an irrational number.

Q.22 ABCD is a parallelogram. Point P divides AB in the ratio 2:3 and point Q divides DC in the ratio 4:1.

Prove that OC is half of OA.

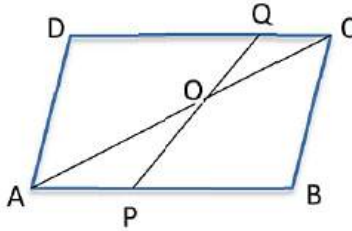

Q.23 From an external point P, two tangents, PA and PB are drawn to a circle with centre O. At a point E on the circle, a tangent is drawn to intersect PA and PB at C and D, respectively. If PA = 10 cm, find the perimeter of  $\Delta PCD$ .

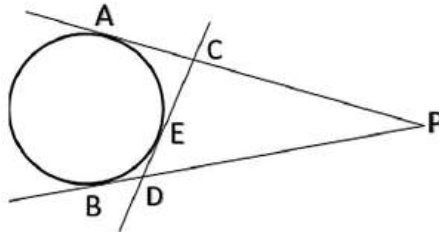

Q.24 If  $\tan (A+B) = \sqrt{3}$  and  $\tan (A-B) = \frac{1}{\sqrt{3}}$   $0^\circ < A+B < 90^\circ$ ;  $A > B$

**OR**

Find the value of x if

$$2 \operatorname{cosec}^3 30 = x \sin^2 60 - \frac{3}{4} \tan^2 30 = 10$$

Q.25 With vertices A, B and C of  $\Delta ABC$  as centres, arcs are drawn with radii 14 cm and the three portions of the triangle so obtained are removed. Find the total area removed from the triangle.

**OR**

Find the area of the unshaded region shown in the given figure.

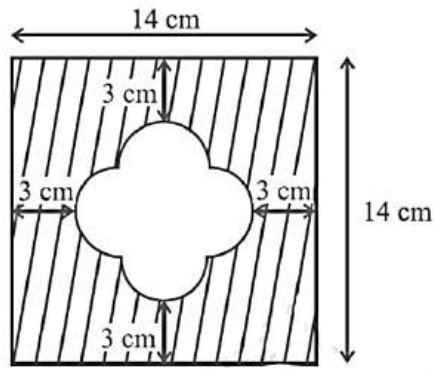

**SECTION-C**

Q.26 National Art convention got registrations from students from all parts of the country, of which 60 are interested in music, 84 are interested in dance and 108 students are interested in handicrafts. For optimum cultural exchange, organisers wish to keep them in minimum number of groups such that each group consists of students interested in the same artform and the number of students in each group is the same. Find the number of students in each group. Find the number of groups in each art form. How many rooms are required if each group will be allotted a room?

Q.27 If  $\alpha, \beta$  are zeroes of quadratic polynomial  $5x^2 + 5x + 1$ , find the value of

(a)  $\alpha^2 + \beta^2$

(b)  $\alpha^{-1} + \beta^{-1}$

Q.28 The sum of a two digit number and the number obtained by reversing the digits is 66. If the digits of the number differ by 2, find the number. How many such numbers are there?

**OR**

Solve :  $\frac{2}{\sqrt{x}} + \frac{3}{\sqrt{y}} = 2$ ;  $\frac{4}{\sqrt{x}} - \frac{9}{\sqrt{y}} = -1, x, y > 0$

Q.29 PA and PB are tangents drawn to a circle of centre O from an external point P. Chord AB makes an angle of  $30^\circ$  with the radius at the point of contact.

If length of the chord is 6 cm, find the length of the tangent PA and the length of the radius OA.

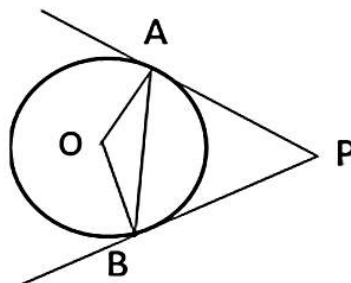

**OR**

Two tangents TP and TQ are drawn to a circle with centre O from an external point T. Prove that  $\angle PTQ = 2\angle OPQ$

Q.30 If  $1 + \sin^2 \theta = 3 \sin \theta \cos \theta$  then prove that  $\tan \theta = 1$  or  $\frac{1}{2}$



Q.31 The length of 40 leaves of a plant are measured correct to nearest millimetre, and the data obtained is represented in the following table.

Length [in mm]	Number of leaves
118 – 126	3
127 – 135	5
136 – 144	9
145 – 153	12
154 – 162	5
163 – 171	4
172 – 180	2

Find the mean length of the leaves.

### SECTION-D

Q.32 A fraction becomes  $\frac{1}{3}$  when 1 is subtracted from the numerator and it becomes  $\frac{1}{4}$  when 8 is added to its denominator find the fraction.

Q.33 (a) State and prove Basic Proportionality theorem.

(b) In the given figure  $\angle CEF = \angle CFE$ . F is the midpoint of DC.

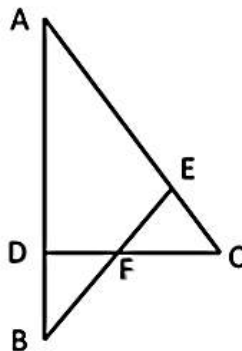

Prove that  $\frac{AB}{BD} = \frac{AE}{FD}$

Q.34 Water is flowing at the rate of 15 km/h through a pipe of diameter 14 cm into a cuboidal pond which is 50 m long and 44 m wide. In what time will the level of water in pond rise by 21 cm?

What should be the speed of water if the rise in water level is to be attained in 1 hour?

**OR**

A tent is in the shape of a cylinder surmounted by a conical top. If the height and radius of the cylindrical part are 3 m and 14 m respectively, and the total height of the tent is 13.5 m, find the area of the canvas required for making the tent, keeping a provision of  $26 \text{ m}^2$  of canvas for stitching and wastage. Also, find the cost of the canvas to be purchased at the rate of Rs. 500 per  $\text{m}^2$ .

Q.35 The median of the following data is 50. Find the values of 'p' and 'q', if the sum of all frequencies is 90. Also find the mode of the data.

Marks obtained	Number of students
20 – 30	p
30 – 40	15
40 – 50	25
50 – 60	20
60 – 70	q
70 – 80	8
80 - 90	10

### SECTION-E

Q.36 Manpreet Kaur is the national record holder for women in the shot-put discipline. Her throw of 18.86m at the Asian Grand Prix in 2017 is the maximum distance for an Indian female athlete.

Keeping her as a role model, Sanjitha is determined to earn gold in Olympics one day.

Initially her throw reached 7.56m only. Being an athlete in school, she regularly practiced both in the mornings and in the evenings and was able to improve the distance by 9cm every week.

During the special camp for 15 days, she started with 40 throws and every day kept increasing the number of throws by 12 to achieve this remarkable progress.



- (a) How many throws Sanjitha practiced on 11<sup>th</sup> day of the camp?
- (b) What would be Sanjitha's throw distance at the end of 6 weeks?

**OR**

When will she be able to achieve a throw of 11.16 m?

- (c) How many throws did she do during the entire camp of 15 days?

Q.37 Tharunya was thrilled to know that the football tournament is fixed with a monthly timeframe from 20th July to 20th August 2023 and for the first time in the FIFA Women's World Cup's history, two nations host in 10 venues.

Her father felt that the game can be better understood if the position of players is represented as points on a coordinate plane.



- (a) At an instance, the midfielders and forward formed a parallelogram. Find the position of the central midfielder (D) if the position of other players who formed the parallelogram are :- A(1,2), B(4,3) and C(6,6)
- (b) Check if the Goal keeper G(-3,5), Sweeper H(3,1) and Wing-back K(0,3) fall on a same straight line.

OR

Check if the Full-back J(5,-3) and centre-back I(-4,6) are equidistant from forward C(0,1) and if C is the mid-point of IJ.

- (c) If Defensive midfielder A(1,4), Attacking midfielder B(2,-3) and Striker E(a,b) lie on the same straight line and B is equidistant from A and E, find the position of E.

Q.38 One evening, Kaushik was in a park. Children were playing cricket. Birds were singing on a nearby tree of height 80m. He observed a bird on the tree at an angle of elevation of  $45^\circ$ .

When a sixer was hit, a ball flew through the tree frightening the bird to fly away. In 2 seconds, he observed the bird flying at the same height at an angle of elevation of  $30^\circ$  and the ball flying towards him at the same height at an angle of elevation of  $60^\circ$ .

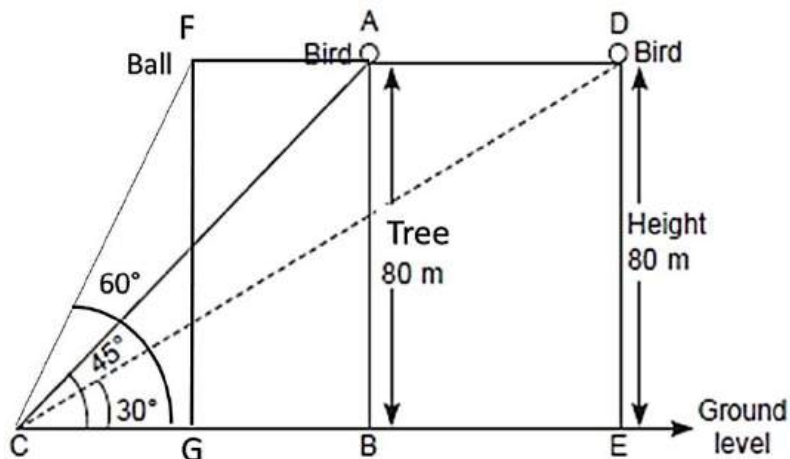

- (a) At what distance from the foot of the tree was he observing the bird sitting on the tree?
- (b) How far did the bird fly in the mentioned time?

OR

After hitting the tree, how far did the ball travel in the sky when Kaushik saw the ball?

(d) What is the speed of the bird in m/min if it had flown  $20(\sqrt{3} + 1)$  m?

## SCIENCE

### General Instructions:

- (i) This question paper consist of 39 questions in 5 sections.
- (ii) All questions are compulsory. However, an internal choice is provided in some questions. A student is expected to attempt only one of these question.
- (iii) **Section-A** consists of 20 Objective Type Questions carrying 1 mark each.
- (iv) **Section-B** consists of 6 Very Short Questions carrying 02 marks each. Answers to these questions should be in the range of 30 to 50 words.
- (v) **Section-C** consists of 7 Short Answer Type Questions carrying 03 marks each. Answers to these questions should be in the range of 50 to 80 words.
- (vi) **Section-D** consists of 3 Long Answer Type Questions carrying 05 marks each. Answers to these questions should be in the range of 80 to 120 words.
- (vii) **Section-E** consists of 3 Source-based/Case-based units of assessment of 04 marks each with sub-parts.

### SECTION-A

Q.1 In the redox reaction:



- (a)  $\text{MnO}_2$  is reduced to  $\text{MnCl}_2$  and  $\text{HCl}$  is oxidized to  $\text{H}_2\text{O}$ .
- (b)  $\text{MnO}_2$  is reduced to  $\text{MnCl}_2$  and  $\text{HCl}$  is oxidized to  $\text{Cl}_2$ .
- (c)  $\text{MnO}_2$  is oxidized to  $\text{MnCl}_2$  and  $\text{HCl}$  is reduced to  $\text{Cl}_2$ .
- (d)  $\text{MnO}_2$  is oxidized to  $\text{MnCl}_2$  and  $\text{HCl}$  is reduced to  $\text{H}_2\text{O}$ .

Q.2 Which of the following is the correct observation of the reaction shown in the given set up?



- (a) Brown Powder of magnesium oxide is formed.
- (b) Colourless gas which turns lime water milky is evolved.

- (c) Magnesium ribbon burns with brilliant white light.  
(d) Reddish brown gas with a smell of burning sulphur has evolved.

Q.3 An element with atomic number \_\_\_\_\_ will form a basic oxide.

- (a) 7 (2,5)                      (b) 17 (2,8,7)                      (c) 14 (2,8,4)                      (d) 11 (2,8,1)

Q.4 Sumedha added a drop of each of diluted acetic acid and diluted hydrochloric acid on pH paper and compared the colors which of the following is the correct conclusion?

- (a) pH of acetic acid is more than that of hydrochloric acid.  
(b) pH of acetic acid is less than that of hydrochloric acid.  
(c) Acetic acid dissociates completely in aqueous solution.  
(d) Acetic acid is strong acid.

Q.5 A farmer wants to grow banana plants genetically similar enough to the plants already available in his field. Which one of the following methods would you suggest for this purpose?

- (a) regeneration                      (b) budding                      (c) vegetative propagation                      (d) sexual reproduction

Q.6 Which of the following features relates to biodegradable substances?

- (a) broken down by biological processes                      (b) remain inert  
(c) persist in environment for long time                      (d) may harm the ecosystem

Q.7 Observe the experimental setup given to you. Name the chemical indicated as 'X' that can absorb the gas which is evolved as a by-product of respiration.

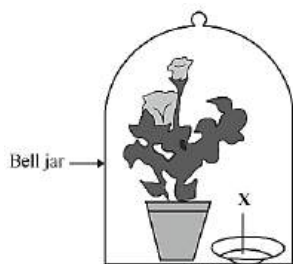

- (a) NaOH                      (b) KOH                      (c) Ca(OH)<sub>2</sub>                      (d) K<sub>2</sub>CO<sub>3</sub>

Q.8 When a small amount of acid is added to water, the phenomena which occur are:

- I. Dilution                      II. Neutralisation                      III. Formation of H<sub>3</sub>O<sup>+</sup> ions                      IV. Salt Formation

The correct statements are:

- (a) (i) and (iii)                      (b) (ii) and (iv)                      (c) (i) and (ii)                      (d) (iii) and (iv)

Q.9 An object is placed at a distance of 40cm in front of a concave mirror of a focal length of 20 cm. The image produced is:

- (a) virtual and inverted  
(b) real and erect  
(c) real, inverted and of the opposite size as that of object

- (d) real, inverted and of the same size as that of object
- Q.10 Two devices are connected between two points say A and B in parallel. The physical quantity that will remain the same between the two points is
- (a) current                      (b) voltage                      (c) resistance                      (d) none of these
- Q.11 The strength of the magnetic field inside a long current carrying straight solenoid is:
- (a) more at the ends than at the centre                      (b) minimum in the middle
- (c) same at all points                      (d) found to increase from one end to the another
- Q.12 Type of lens used in correction of myopia:
- (a) convex lens                      (b) concave lens                      (c) reflecting lens                      (d) bifocal lens
- Q.13 From the list given below, select the character which can be acquired but not inherited.
- (a) colour of eye                      (b) colour of skin                      (c) size of body                      (d) nature of hair
- Q.14 The organ through which the developing foetus obtains its food from the mother is:
- (a) ureter                      (b) placenta                      (c) uterus                      (d) zygote
- Q.15 Two plant hormones which regulate growth of plant are?
- (a) cytokinin and auxin                      (b) abscisic acid and auxin
- (c) auxin and gibberellin                      (d) all of these
- Q.16 An element 'A' is soft and can be cut with a knife. This is very reactive to air and cannot be kept in air. Identify the element.
- (a) Mg                      (b) P                      (c) Ca                      (d) Na

**Question no. 17 to 20 are Assertion and Reason based questions.**

These questions consist of two statements: Assertion (A) and Reason (R). Answer these questions selecting the appropriate option given below:

- (a) Both Assertion (A) and Reason (R) are true and Reason (R) is a correct explanation of Assertion (A)
- (b) Both Assertion (A) and Reason (R) are true but Reason (R) is not the correct explanation of Assertion (A)
- (c) A is true but R is false
- (d) A is false but R is true
- Q.17 Assertion (A): Gas bubbles are observed when sodium carbonate is added to dilute HCl.
- Reason (R):  $\text{CO}_2$  is given off in the reaction.
- Q.18 Assertion (A): Height in pea plants is controlled by efficiency of enzymes and is thus genetically controlled.
- Reason (R): Cellular DNA is the information source for making proteins in the cell.

Q.19 Assertion (A): A beam of white light gives a spectrum on passing through a glass prism.

Reason (R): Speed of light outside the prism is different from speed of light inside the prism.

Q.20 Assertion (A): In humans, males play an important role in determining the sex of the child.

Reason (R): Males have two X chromosomes.

### SECTION-B

Q.21 When  $H_2$  gas is passed over heated copper (II) oxide, copper and steam are formed. Write the balanced chemical equation with physical states for this reaction. State what kind of chemical reaction is this?

Q.22 Why is chemical communication better than electrical impulse as a means of communication between cells in a multi-cellular organism?

Q.23 Patients whose gall bladder are removed are recommended to eat less oily food. Why?

**OR**

Which is the largest digestive gland in human body? What is the name and function of its secretion?

Q.24 A dentist used a mirror in front of a decayed tooth at a distance of 4 cm from the tooth to get a four times magnified erect image in the mirror. Use mirror formula to find the focal length and nature of the mirror used.

Q.25 The refractive indices of three media are given below:

Medium	Refractive index
A	1.6
B	1.8
C	1.5

A ray of light travelling from A to B and another ray is travelling from B to C.

(a) In which of two cases the refracted ray bends towards the normal?

(b) In which case does the speed of light increase in the second medium?

**OR**

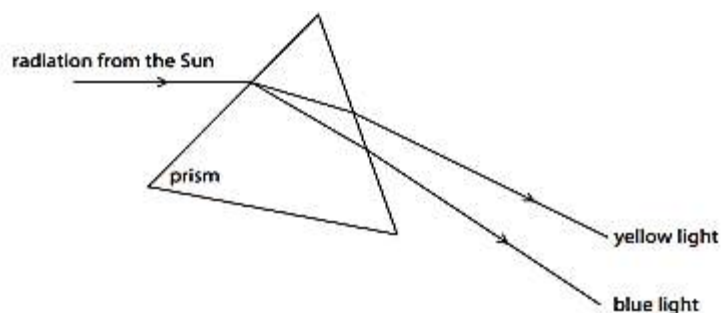

State the phenomena observed in above diagram. Explain with reference to the diagram, which of two lights mentioned above will have higher wavelength?

Q.26 The amount of energy that is available to the plants from the sun is 200000 J. Calculate the amount of energy available to the lion in the following food chain.

Plant → Deer → Lion

### SECTION-C

Q.27 Write chemical equations for the reactions taking place when:

- (a) magnesium reacts with dilute  $\text{HNO}_3$
- (b) sodium reacts with water
- (c) zinc reacts with dilute hydrochloric acid

Q.28 A compound 'X' of sodium is commonly used for making crispy Pakoras. It is also used for curing acidity in the stomach. Identify X. Write its formula and its chemical name. State the reaction that take place when it is heated.

**OR**

An element 'M' with electronic configuration 2,8,3 combines separately with  $\text{Cl}^-$ ,  $\text{SO}_4^{2-}$  anions. Write the chemical formulae of the compounds formed. Predict with the suitable reason the nature of the bond formed by element 'M' in general. How will the electrical conductivity of the compounds formed vary with respect to 'M'?

Q.29 State the source of secretion and function of the following hormones.

- (a) thyroxin
- (b) insulin
- (c) growth hormone

Q.30 Explain the method of sex determination in humans.

Q.31 Why are bacteria and fungi called decomposers? List any two advantages of decomposers.

Q.32 A 5 cm tall object is placed perpendicular to the principal axis of a convex lens of focal length 20 cm. The distance of the object from the lens is 30 cm. Find the

- (a) position
- (b) nature and
- (c) size of the image formed

Q.33 What is a solenoid? Draw magnetic field lines due to current-carrying solenoid. Write important features of the magnetic field obtained.

### SECTION-D

Q.34 (a) What is water of crystallisation? Write the common name and chemical formula of a compound which has ten water molecules as water crystallisation.

(b) How is this compound obtained? Write the chemical equation. List any two uses of this compound.

**OR**

On heating blue coloured powder of copper (II) nitrate in a boiling tube, copper oxide (black), oxygen gas and a brown gas X is formed.

(a) Write a balanced chemical equation of the reaction.

(b) Identify the brown gas X evolved.

(c) Identify the type of reaction.

(d) What could be the pH range of aqueous solution of the gas X.

Q.35 Draw a neat diagram of human male reproductive system and label the parts performing the following function.



- (a) Production of sperms.
- (b) Common passage for sperms and urine.
- (c) Gland which provides fluid.
- (d) Provides low temperature for the formation of sperms.

**OR**

With the help of a diagram describe the structure of a flower and explain the role of each part.

- Q.36 (a) Find the current flowing through the following electric circuit.

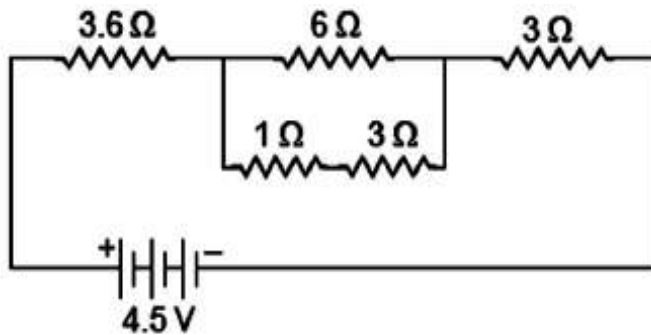

- (b) A  $5\ \Omega$  resistor is connected across a battery of 6 volts. Calculate the energy dissipates as heat in 10 seconds.

**OR**

Two resistors with resistance of  $10\ \Omega$  and  $15\ \Omega$  are connected to a battery of 12 V so as to obtain and measure:

- (a) minimum electric current
- (b) maximum electric current
- (i) State the mode of connecting the resistors in each case with the help of a circuit diagram.
- (ii) Calculate the strength of total electric current in the circuit in each case.

### SECTION-E

#### **Case-Based Questions:**

- Q.37 Read the paragraph given below and answer the questions that follow:

A scale for measuring hydrogen ion concentration in a solution, called pH scale has been developed. The p in the pH scale stands for 'Potenz' in German, measuring power on the pH scale we can measure pH generally from 0 to 14 pH should be thought of simply as a number which indicated the acidic or basic nature of a solution.

- (a) What does the scale represent when pH value increases from 7 to 14?
- (b) What is the pH value of milk of magnesia?

(c) What is the role of pH in everyday life.

**OR**

(c) What happens when the pH of mouth is lower than 5.5?

Q.38 Read the paragraph and answer the questions that follow:

If the body design in the squirrel relied only on electrical impulses via nerve cells, the range of tissues instructed to prepare for the coming activity would be limited on the other hand, if a chemical signal were to be sent as well, it would reach all cells of the body and provide the wide ranging changes needed. This is done in many animals, including human beings, using a hormone called adrenaline that is secreted from adrenal gland.

(a) Which is the target organ for the adrenaline hormone?

(b) Which hormone released by ovary?

(c) What are Phytohormones?

**OR**

(c) What are endocrine glands?

Q.39 Read the paragraph and answer the questions that follow:

The above images are that of a specialized slide projector. Slides are small transparencies mounted in sturdy frames ideally suited to magnification and projection, since they have a very high resolution and a high image quality. There is a tray where the slides are to be put into a particular orientation so that the viewers can see the enlarged erect images of the transparent slides. This means that the slides will have to be inserted upside down in the projector tray.

To show her students the images of insects that she investigated in the lab, Mrs. Iyer brought a slide projector. Her slide projector produced a 500 times enlarged and inverted image of a slide on a screen 10 m away.

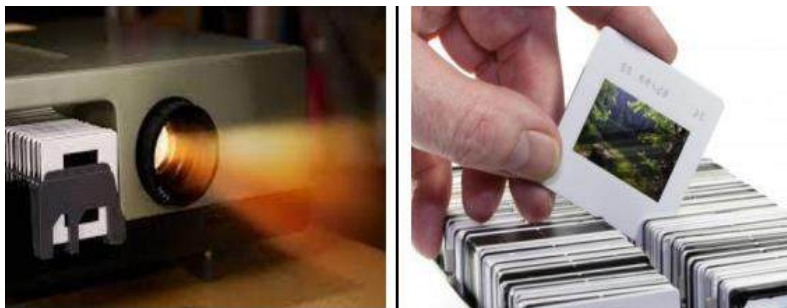

(a) What type of image is formed by slide projector?

(b) What kind of lens does slide projector have?

(c) A slide projector has a lens of focal length 20 cm. The slide is placed upside down 21 cm from the lens. How far away the screen should be placed from the projector's lens.

OR

(c) What is the power of a convex lens if its focal length is 25 cm?

## SOCIAL SCIENCE

### General Instructions:

- (i) This question paper comprises Six Sections- A, B, C, D, E and F. There are 37 questions in the Question paper. All questions are compulsory.
- (ii) Section A - Questions No. 1 to 20 are Objective Type Questions of 1 mark each.
- (iii) Section B - Questions No. 21 to 24 are Very Short Answer Type Questions, carrying 2 marks each. Answer to each question should not exceed 40 words.
- (iv) Section C - Questions No. 25 to 29 are Short Answer Type Questions, carrying 3 marks each. Answer to each question should not exceed 60 words.
- (v) Section D - Questions No. 30 to 33 are Long Answer Type Questions, carrying 5 marks each. Answer to each question should not exceed 80 words.
- (vi) Section E - Questions No. 34 to 36 are Case-Based Questions with three sub questions and are of 4 marks each.
- (vii) Section F - Questions No. 37 is Map based Question, carrying 5 marks with two parts, 37 (a) from History (2 marks) and 37 (b) from Geography (3 marks).
- (viii) There is no overall choice in the question paper. However, an internal choice has been provided in a few questions. Only one of the choices in such questions has to be attempted.
- (ix) In addition to this, separate instructions are given with each section and question, wherever necessary.
- (x) **Note:** CBQ stands for "Competency Based Questions" 50% Weightage allocated for competency based question.

### SECTION-A

- Q.1 Elle the measuring unit in Germany was used to measure
- (a) cloth                      (b) thread                      (c) land                      (d) height
- Q.2 Why had Congress ignored the dalits for long?
- (a) due to their liberal outlook                      (b) due to fear from Britishers
- (c) for fear of offending the Sanatanis                      (d) for the fear of Dr. B.R. Ambedkar
- Q.3 'Silk route' refers to
- (a) Network of routes connecting China and Rome.
- (b) Network of routes connecting India and Rome.
- (c) Network of routes connecting China and South America.
- (d) Network of routes connecting Asia with Europe and Northern Africa.
- Q.4 Who said "Printing is the ultimate gift of God and the greatest one"
- (a) Charles Dickens                      (b) J.V. Schely                      (c) Mahatma Gandhi                      (d) Martin Luther

**For Question numbers 5 and 8, two statements are given as Assertion (A) and Reason (R). Select the correct answers to these questions from the codes (a), (b), (c) and (d) as given below:**

Q.5 Assertion (A): Iron ore is the basic mineral and the backbone of the Industrial development.

Reason (R): Magnetite is the finest iron ore.

(a) Both A and R are true and R is the correct explanation of A.

(b) Both A and R are true but R is not the correct explanation of A.

(c) A is true but R is false.

(d) A is false but R is true.

Q.6 \_\_\_\_\_ is a major power providing corporation in India.

(a) NTPC

(b) RBI

(c) HAIL

(d) SAIL

Q.7 What is JFM?

Q.8 Assertion (A): Agriculture and industry move hand in hand.

Reason (R): Industrial development is a precondition for eradication of unemployment and poverty from the country.

(a) Both A and R are true and R is the correct explanation of A.

(b) Both A and R are true but R is not the correct explanation of A.

(c) A is true but R is false.

(d) A is false but R is true.

Q.9 Fill in the blank:

\_\_\_\_\_ soil is known as regur soil and ideal for growing \_\_\_\_\_.

Q.10 \_\_\_\_\_ emerged as an independent country in 1948.

Q.11 Complete the box by choosing the correct option:

Village Panchayat	Sarpanch
Municipal Corporation	?

Q.12 Correct the following statements and rewrite:

One third of seats in Indian Parliament are reserved for women.

Q.13 A recognised political party is one that

(a) is registered with the election commission of India.

(b) is given a unique election symbol

(c) gets some other facilities recognised by the election commission

(d) all of these

Q.14 Picture Based Question:

Which of the following options best signifies this cartoon?



(a) perils of discussions and debates

(b) perils of transparency

(c) perils of accountability

(d) perils of running coalition government

Q.15 On which of issues most of the democracies have failed?

(I) corruption

(II) removal of poverty

(III) political equality

(IV) right to vote

(a) only (I) and (II)

(b) only (II) and (III)

(c) only (III) and (IV)

(d) all of the above

Q.16 Life expectancy at birth means:

(a) Average expected length of life of a person at the time of birth

(b) Average expected length of life of a person at the time of death

(c) Average expected length of a child at the time of birth

(d) none of the above

Q.17 What are intermediate goods?

Q.18 Which of the following is a formal source of credit?

(a) money lenders

(b) trader

(c) self-help groups

(d) commercial banks

Q.19 Removing barriers or restrictions set up by the government is known as \_\_\_\_\_.

(a) privatisation

(b) globalisation

(c) liberalisation

(d) industrialisation

Q.20 What is globalisation?

**OR**

What are trade barriers?

### **SECTION-B**

Q.21 Define terms of credit.

Q.22 What are feminist movements? What were their major demands?

Q.23 Why were there clashes between weavers and gomasthas?

**OR**

What was vernacular press act?

Q.24 What are the reasons why the banks might not be willing to lend to certain borrowers?

**SECTION-C**

Q.25 Who supervises the functioning of banks? In what ways is the supervision done?

Q.26 What are the objectives of MGNREGA 2005?

Q.27 "There is an overwhelming support for the idea of democracy all over the world." Support the statement.

Q.28 Explain any three factors for the localisation of an industry in a particular area?

Q.29 Who was marco polo? What was his contribution to print culture?

**SECTION-D**

Q.30 "The Bengal Gazette was a commercial paper open to all, but influenced by none." Justify the claim of James Augustus Hickey.

**OR**

Describe the contribution made by Alluri Sitaram Raju to the non-cooperation movement in Andhra Pradesh.

Q.31 Compare the Gondwana Coalfields with the tertiary coalfields.

**OR**

Why are Multipurpose projects facing resistance? Explain with five reasons.

Q.32 What is the difference between prudential and moral reasons for power sharing?

**OR**

Mention any five main features which make India a federal country.

Q.33 How to create more employment in rural areas? Explain with examples.

**OR**

Explain the role of self help groups in the rural economy.

**SECTION-E**

Q.34 Case-Based Question:

The aim of the Zollverein is to bind the Germans economically into a nation. It will strengthen the nation materially as much by protecting its internal productivity. It ought to awaken and raise national sentiment through a fusion of individual and provincial interests. The German people have realised that a free economic system is the only means to engender national feeling.

(a) Zollverein was formed at the initiative of \_\_\_\_\_.

(b) What was the basic objective of Zollverein?

(c) State any two steps taken under Zollverein for economic freedom.

(d) In which year Zollverein was formed?

Q.35 Given the abundance and renewability of water, It is difficult to imagine that we may suffer from water scarcity. The moment we speak of water shortage, we immediately associate it with regions having low rainfall or those that

are drought prone. We instantaneously visualise the desert of Rajasthan and women balancing many 'matkas' (earthen pots) used for collecting and storing water and travelling long distances to get water.

- (a) Define water scarcity.
- (b) State any three reasons for water scarcity.
- (c) Suggest any two ways to solve the problem of water scarcity in urban area.
- (d) Tanka is rainwater harvesting technique associated with which of the state?

Q.36 Sri Lanka emerged as an independent country in 1948. The leaders of the Sinhala community sought to secure dominance over government by virtue of their majority. As a result, the democratically elected government adopted a series of majoritarian measures to establish Sinhala Supremacy.

Answer the following MCQs:

- (a) What do you understand by majoritarianism?
  - (i) Rule of the majority
  - (ii) Laws of the country are based on the will of the majority
  - (iii) Language of the majority is declared as the official language
  - (iv) all of the above
- (b) Name the community, which was in minority in Sri Lanka.
  - (i) Indian Tamils      (ii) Sri-Lanka Tamils      (iii) others      (iv) only (i) and (ii)
- (c) How did the government of Sri-Lanka increase the problem of ethnic conflict?
  - (i) power sharing      (ii) federal distribution of powers
  - (iii) majoritarianism      (iv) system of checks and balances
- (d) Why should the principle of power sharing be followed by the countries?
  - (i) It prevents disintegration of the country.      (ii) It prevents ethnic conflicts
  - (iii) It enhances the democratic spirit      (iv) All of the above

### SECTION-F

Map Based Question:

Q.37 (A) Two places 'A' and 'B' are marked on the given political outline *Map of India*. Identify these features with the help of the following information and write their correct names on the lines drawn near them.

A– A place associated with the cotton mill workers Satyagraha.

B– Congress session- September 1920

(B) On the given outline *Political Map of India*, Locate any three:

(a) A major Jute producing state

(d) Digboil (oil fields)

(b) Kalpakkam Nuclear Plant

(e) Kudremukh (iron ore mines)

(c) Noida (Software Technology Park)

